

(No Model.)

3 Sheets—Sheet 1.

E. RIVETT.

WATCH MAKER'S LATHE.

No. 363,000.

Patented May 17, 1887.

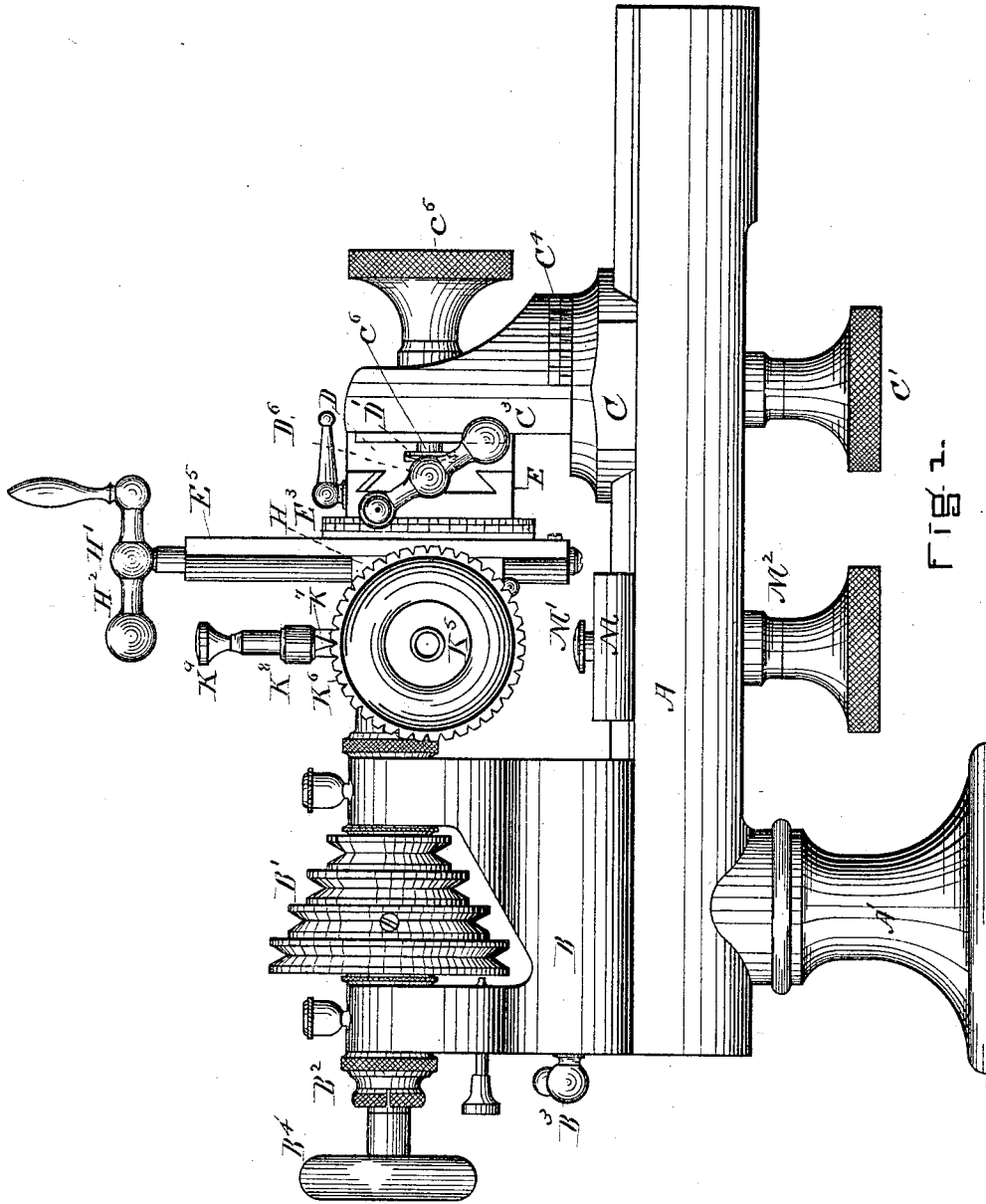

WITNESSES.

*Frank G. Parker*  
*William Edison*

INVENTOR.

*Edward Rivett*

(No Model.)

3 Sheets—Sheet 2.

E. RIVETT.  
WATCH MAKER'S LATHE.

No. 363,000.

Patented May 17, 1887.

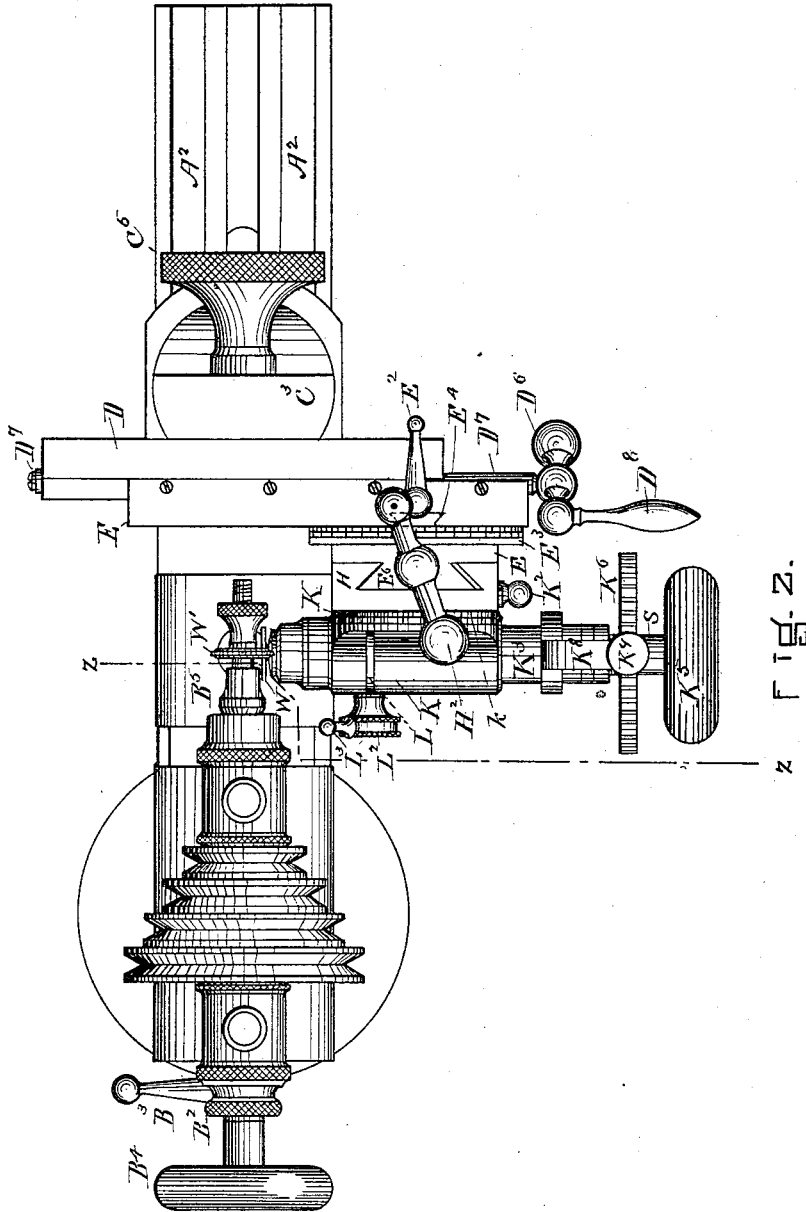

FIG. 2.

WITNESSES.

*Frank M. Parker*  
*William Edson*

INVENTOR.

*Edward Rivett*

E. RIVETT.

WATCH MAKER'S LATHE.

No. 363,000.

Patented May 17, 1887.

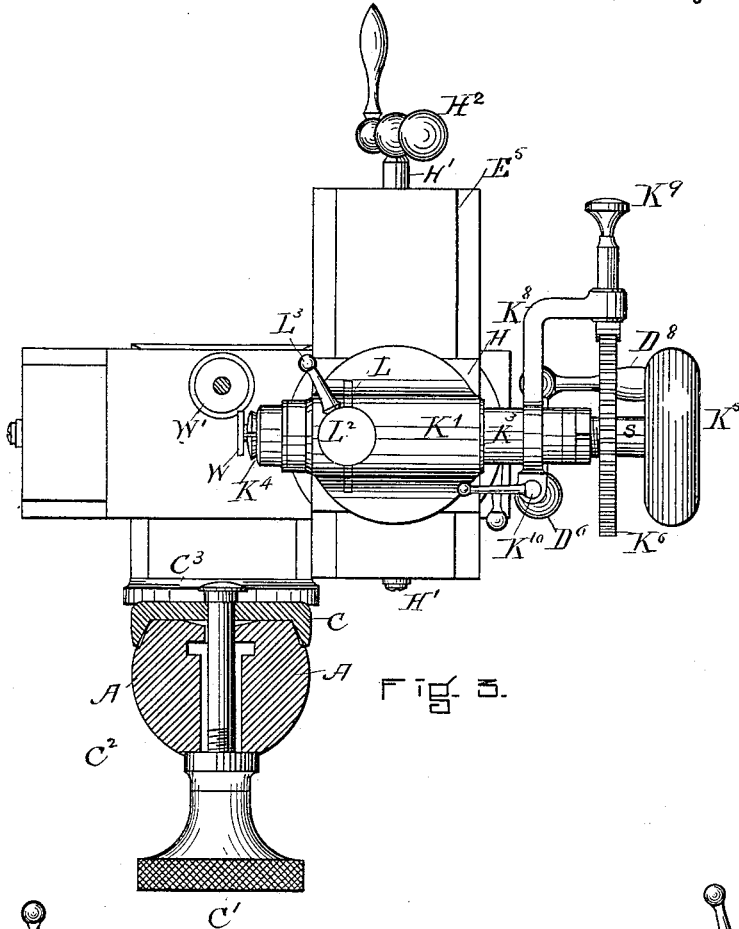

Fig. 3.

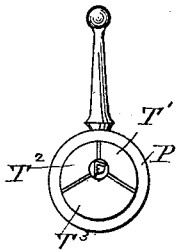

Fig. 5.

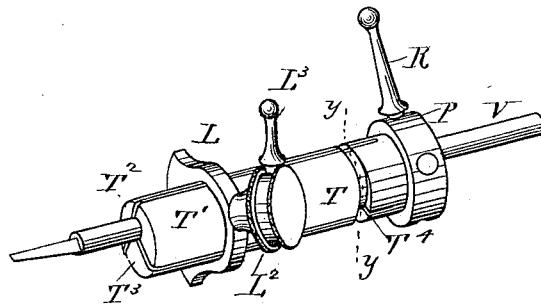

Fig. 4.

WITNESSES.

*Frank A. Parker*  
*William Edison*

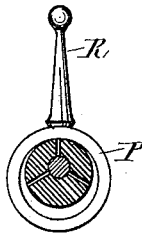

Fig. 6.

INVENTOR.

*Edward Rivett*

# UNITED STATES PATENT OFFICE.

EDWARD RIVETT, OF BOSTON, MASSACHUSETTS.

## WATCH-MAKER'S LATHE.

SPECIFICATION forming part of Letters Patent No. 363,000, dated May 17, 1887.

Application filed December 3, 1886. Serial No. 220,631. (No model.)

*To all whom it may concern:*

Be it known that I, EDWARD RIVETT, of Boston, in the county of Suffolk and State of Massachusetts, have invented new and useful Improvements in Watch-Makers' Lathes, of which the following, taken in connection with the accompanying drawings, is a specification.

My invention consists in combining with the shears and head-stock of a lathe certain new devices, the objects of which are to increase the automatic features of the lathe, so as to render it much more useful as an instrument; also, to render it capable of working upon articles at all angles with equal accuracy, and to so construct the several parts that the slide-rest may be readily attached to the tail-stock of the lathe; also, to improve the details of the tool-holding parts of the lathe. These objects I accomplish by the mechanisms shown in the accompanying drawings, in which—

Figure 1 is an elevation of the lathe with my improvements attached. Fig. 2 is a plan of the same. Fig. 3 is a view taken partly in cross vertical section and partly in end elevation, the view being taken on section-line ZZ of Fig. 2. Fig. 4 is a perspective of an improved tool-holder which I use in my slide-rest. Fig. 5 is an end elevation of the improved tool-holder; and Fig. 6 is a cross-section through my improved tool-holder, taken on the line *yy* of Fig. 4.

Although my lathe is more especially adapted to watch-work, it may be used on all kinds of work requiring great accuracy, and may be adapted to be used on quite large lathes, and its use may be varied to an unlimited extent.

In the drawings, A represents the bed of the lathe, which is supported by a standard, A', and is provided with ways for the head-stock, tail-stock, and other similar parts to slide upon.

The head-stock B, Figs. 1 and 2, is made substantially as other head-stocks of this class are made, and is provided with a clamping device, B<sup>2</sup>, for attaching it to the bed of the lathe; also with coned pulley B<sup>1</sup>, hollow spindle B<sup>3</sup>, back handle, B<sup>4</sup>, chuck B<sup>5</sup>, and other parts similar to those in use and this kind of a lathe, none of which requires a particular description, as they are well known and in common use.

The tail-stock, which I will now describe, is peculiar in its construction and use, and consists of a base or sliding piece, C, Figs. 1, 2, and 3, upon which is mounted a post, C<sup>1</sup>, 55 which, together with the sliding base-piece C, may be clamped to the bed A by means of the bolt C<sup>2</sup> and hand-screw C<sup>3</sup>, Fig. 3.

The post C<sup>1</sup> has a circular graduated base, C<sup>4</sup>, Fig. 2, and is free to turn on its perpendicular axis when the clamping-screw C<sup>3</sup>, Fig. 3, is loose. A zero-mark (not shown) is made on the base-piece C, by the aid of which and the graduation C<sup>4</sup> on the base of the post C<sup>1</sup> the vertical plane forming the front face of 65 the said post may be set at any horizontal angle with the axial line of the lathe.

To the front face of the post C<sup>1</sup>, I attach, by means of the clamping screw-bolt C<sup>5</sup>, Fig. 1, and hand screw C<sup>6</sup>, a gage-rest device, which 70 consists of a base-piece, D, Figs. 1 and 2, held by the screw-bolt C<sup>5</sup>, and being adjustable longitudinally across the face of the post C<sup>1</sup>, having no other motion except its motion with the post C<sup>1</sup>—that is, it will slide back and forth 75 with the post on the axial line of the lathe, and it will turn with the post so as to form any desired horizontal angle with the axial line of the lathe.

E, Figs. 1 and 2, is a slide that is moved 80 back and forth across the axial line of the lathe upon the slide D by means of the screw and crank D<sup>1</sup> D<sup>2</sup> D<sup>3</sup>, Fig. 2. To the slide E, by means of a pivot, (not shown,) I attach a swiveling base-plate, E<sup>1</sup> E<sup>2</sup> E<sup>3</sup>. This base-plate 85 E<sup>1</sup> E<sup>2</sup> E<sup>3</sup> is clamped into position by means of a wedge-key, E<sup>4</sup>, and a screw, E<sup>5</sup>, Fig. 2, and may be set at any angle in the plane of slide E, and has graduation on the part E<sup>2</sup>, as shown in Fig. 2. The base-plate E<sup>1</sup> E<sup>2</sup> E<sup>3</sup> (see Fig. 2) 90 has upon it a sliding block, H, which serves as a base for the tool-post K'. Said tool-post K' is attached by a pivot, (not shown,) and swivels on the block H, being clamped to said block by means of the wedge-key and screw 95 device at K<sup>2</sup>, same as shown at E<sup>4</sup> and E<sup>5</sup>, Fig. 2, for holding the base-plate E<sup>1</sup> E<sup>2</sup> E<sup>3</sup>, above referred to.

Within the tool-post K', I have a tool-holder, K, and clamping-chuck K<sup>1</sup>, Fig. 2, made in 100 the usual manner, and provided with a locking device, L L<sup>1</sup> L<sup>2</sup>, Figs. 3 and 4. This lock-

ing device consists of a throttling-ring, L, and a tightening-screw, L<sup>2</sup> L<sup>3</sup>—a well-known device that does not require further description.

K<sup>5</sup>, Figs. 2 and 3, is a hand-wheel for revolving the tool-holder and its parts.

K<sup>6</sup>, Figs. 1 and 5, represents a notched or graduated disk for guiding the operator when using this device for cutting gear-wheels, and is connected to clutch-spindle S by a pin or other device in common use. The turning of the clamping-chuck spindle and chuck when a wheel-gear, W, Figs. 2 and 3, is to be cut by the cutter W' is regulated by an arm, K<sup>8</sup>, locked to the tool-holder K<sup>3</sup> by a clamp, K<sup>10</sup>, said arm K<sup>8</sup> holding a spring stop or latch, K<sup>7</sup> K<sup>9</sup>, in Fig. 1.

When desirable to use above-described gage-rest and tool-holder in the ordinary manner, the whole device may be removed from the post C<sup>3</sup> and placed upon the sliding base M, Fig. 1, and then clamped by the bolt M' and hand-wheel M<sup>2</sup>.

In Figs. 4, 5, and 6 I have shown a modification of the tool-holder K<sup>3</sup>. This improvement consists in making in the tool-holder a hole for the tool V, that is not concentric with the hole in the tool-post K', and in making its kerfs radiate from the eccentric hole that holds the tool V. To equalize the spring of the parts T' T<sup>2</sup> T<sup>3</sup> under the pressure of the throttling-piece L, although the parts T' T<sup>2</sup> T<sup>3</sup> are unequal in section originally, the cut T is made so as to make them of about the same tension, and thus cause them to close in onto the tool V with about the same pressure.

The object of the eccentric tool-holder T, Fig. 4, is that the operator may make slight changes in the place of the tool V by simply turning the eccentric tool-holder T, and without changing the position of any of the other parts.

A graduation is made, as shown at k, Fig. 2, on the base of the tool-holder K, for convenience in adjusting the holder when beveled wheels are cut, said wheels being held by the tool-holder, and cut by a cutter running in the lathe.

The tool-holder K has clamping chuck at its end adjusted to tools of all descriptions, and also to receive and hold work, or, in other words, articles to be acted upon by cutting, milling, and other tools connected to a device driven by the lathe-spindle; but the tool-holder T, Figs. 4, 5, and 6, has an eccentric clamping-chuck, and is especially adapted for holding tools which require slight changes in their place or angular relations to the "work" in the lathe.

As the outside diameters of the tool-holders K and T are the same, it is evident that either will fit the tool-holder K<sup>3</sup> equally well and may be interchanged.

The tool-holding clamping-chuck K<sup>4</sup>, Fig. 3, is of the kind sometimes called a "split chuck," surrounded by a quill, (like K<sup>3</sup>, Fig. 3.)

By my construction of the gage-rest and tail-stock, as described, I am enabled to change the machine that I call a "lathe," and which in itself is a most perfect lathe, into a milling-machine capable of doing any work required of a milling-machine.

I claim—

1. In a lathe, the combination of the bed A, and sliding tail stock C C<sup>3</sup>, and gage-rest tool-support D, with the adjusting parts E H K and their adjuncts, connected as described, whereby the lathe is converted into a milling-machine, substantially as described, and for the purpose set forth.

2. In a lathe, the combination, with the bed A and sliding base-piece C, of the revoluble tail-stock part C<sup>3</sup> and gage-rest support D, operating together substantially as described, and for the purpose set forth.

3. In a lathe, the combination of the bed A, sliding base C, and revoluble tail-stock part C<sup>3</sup>, with the gage-rest support D, tool-holder K, tool-post K', and clamping-chuck K<sup>4</sup>, all operating together substantially as described, and for the purpose set forth.

EDWARD RIVETT.

Witnesses:

WILLIAM EDSON,  
JOS. A. FRATUS.